

Proprietary rights are included in the information disclosed herein. This information is submitted in confidence and neither the document nor the information disclosed herein shall be reproduced or transferred to other documents for manufacturing or for any other purpose except as specifically authorized in writing by ARE Telecom & Wind.

REVISIONS			
REV.	DESCRIPTION	DATE	APPROVED
A	initial release	2/18/21	MGC
B			

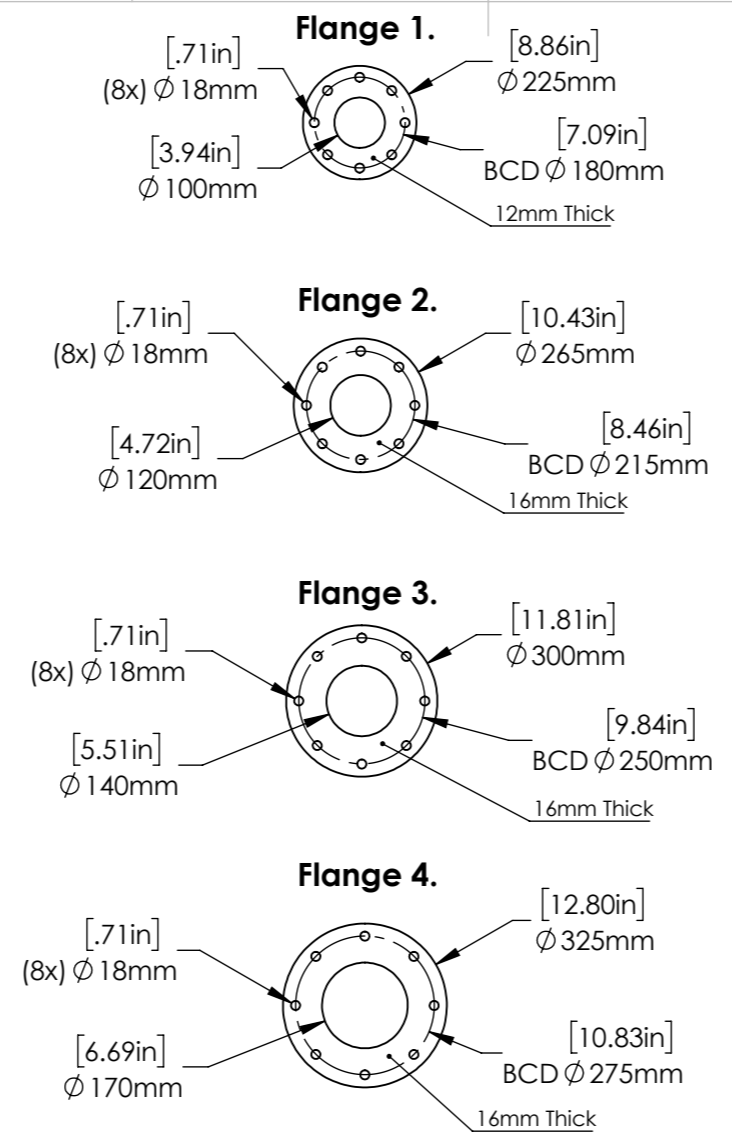
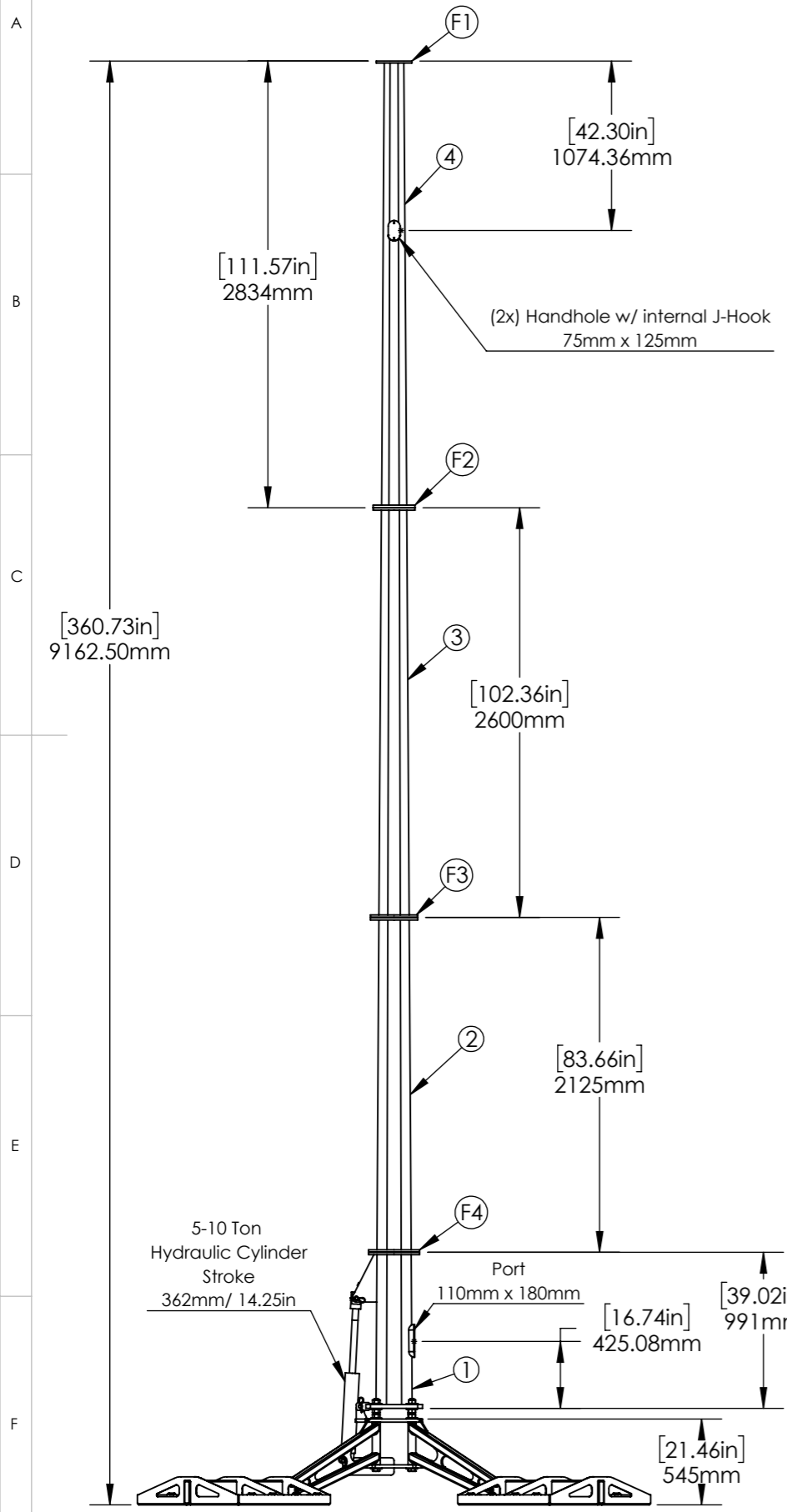

- Survival Wind Speed: Per Code
 - Class - Per Code
 - Topo - Per Code
 - Exposure - Per Code
- Design and Welding Codes:
 - TIA-222-G
 - AWS D1.1
- Material
 - Pole: Q355 (ASTM A572 GR50)
 - Baseplate: Q355 (ASTM A572 GR50)
 - Splice Plates/ Flanges: Q355 (ASTM A572 GR50)
- Pole has 8 sides
- Finish: Hot dip Galvanizing per ASTM A123
- Anchor Bolts: (4X) M24x3 x 445mm (150mm thread length)
 - Grade 8.8 w/ (3x) nuts & (4x) washers ea.
 - (Optional) ASTM F1554 GR55
 - BCD 320mm/ 12.6in
- Flange/ Tray Bolts: (48x) M16x2 x 60mm
 - Grade 8.8 w/ nut and (2x) washer ea.
 - (Optional) 5/8-11 x 2.5" A325

8. Pole Section Details

Pole Section	#1	#2	#3	#4
Thickness (mm)/ (in)	4/ 0.158	4/ 0.158	4/ 0.158	4/ 0.158
Length (m)/ (ft)	0.991/ 3.25	2.125/ 7.06	2.6/ 8.53	2.834/ 9.3
Top Dia. (mm)/ (in)	218/ 8.58	192/ 7.56	160/ 6.3	125/ 4.92
Bottom Dia. (mm)/ (in)	230/ 9.1	218/ 8.58	192/ 7.56	160/ 6.3
Design Slip Fit (mm)/ (in)	NA	NA	NA	
Weight (kg)/ (lb)	59/ 130	59/ 130	58/ 128	46/ 101

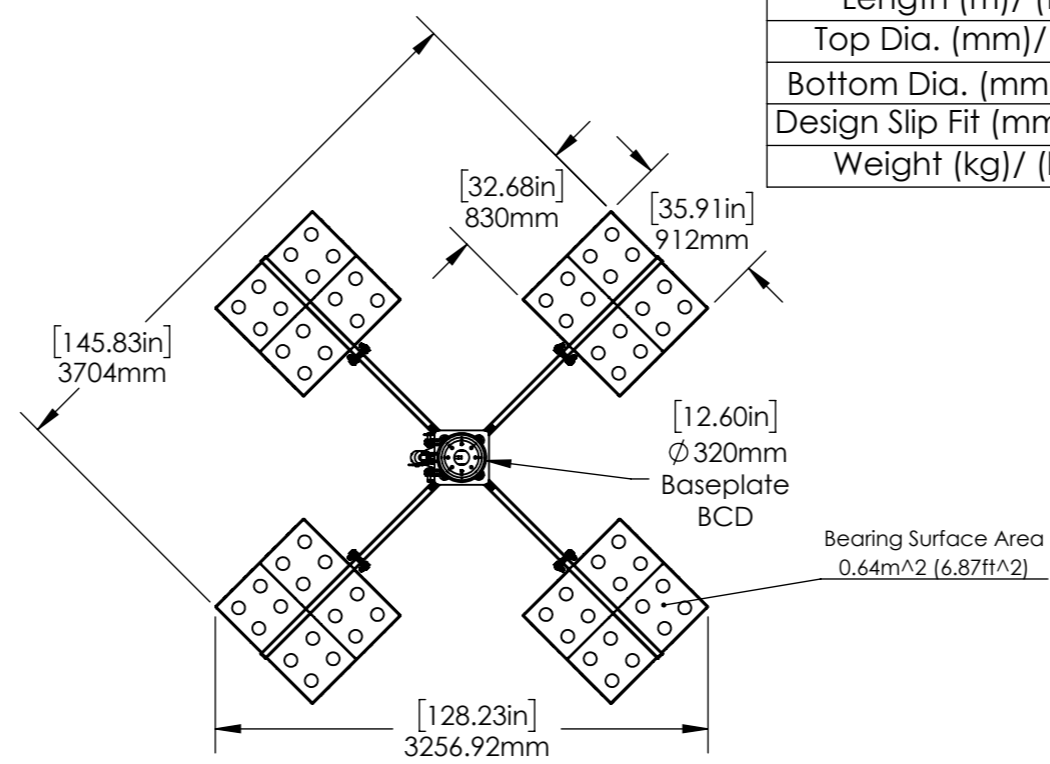

- Ballast Requirements:**
- Concrete Pavers 407mm x 407mm x 50mm (16" x 16" x 2")
 - Minimum Weight per Tray 455kg (1000lb)
 - Minimum Ultimate Bearing Pressure 120kPa (2500psf)

Steel Weight Pole - 222kg/ 488.4lb Foundation - 326/ 717lb	APPROVALS DRAWN MGC CHECKED RESP ENG MFG ENG QUAL ENG	DATE 2/18/21	<p>ARE Telecom & Wind 1041 Grand Ave., #213 St Paul, MN 55105 (651) 330 1263</p> <p>AFS200 9m 4SF 5t-10t Hyd/ Jack</p>
MATERIAL See Notes FINISH See Notes DO NOT SCALE DRAWING	CAD-generated drawing do not manually update Details and dimensions not shown on this drawing can be found in CAD file. scale NA rev. A size NA sheet 1 of 2		

Proprietary rights are included in the information disclosed herein. This information is submitted in confidence and neither the document nor the information disclosed here-in shall be reproduced or transferred to other documents for manufacturing or for any other purpose except as specifically authorized in writing by ARE Telecom & Wind.

REVISIONS			
REV.	DESCRIPTION	DATE	APPROVED
A	initial release	1/12/21	MGC

Notes 3:

- All plate and tube material shall have a minimum yield strength of 355 MPa (50 ksi)
- All welding shall conform to the minimum requirements of AWS D1.1
- All welding shall be done by welders qualified under AWS specifications, using E70XX, low hydrogen electrodes
- All components shall be Hot Dip Galvanized in accordance with ASTM A123
- Debur all sharp edges

AFS200 Bill of Materials			
#	DESCRIPTION	QTY.	Weight (kg/ lbs)
1	Ballast Tray	4	49.5/ 109
2	Upper Splice Plate	1	19/ 42
3	Lower Splice Plate	1	24/ 53
4	Outrigger	4	18.5/ 41
5	20mm x 80mm Clevis w/ Cotter Pin	4	3.5/ 7.7

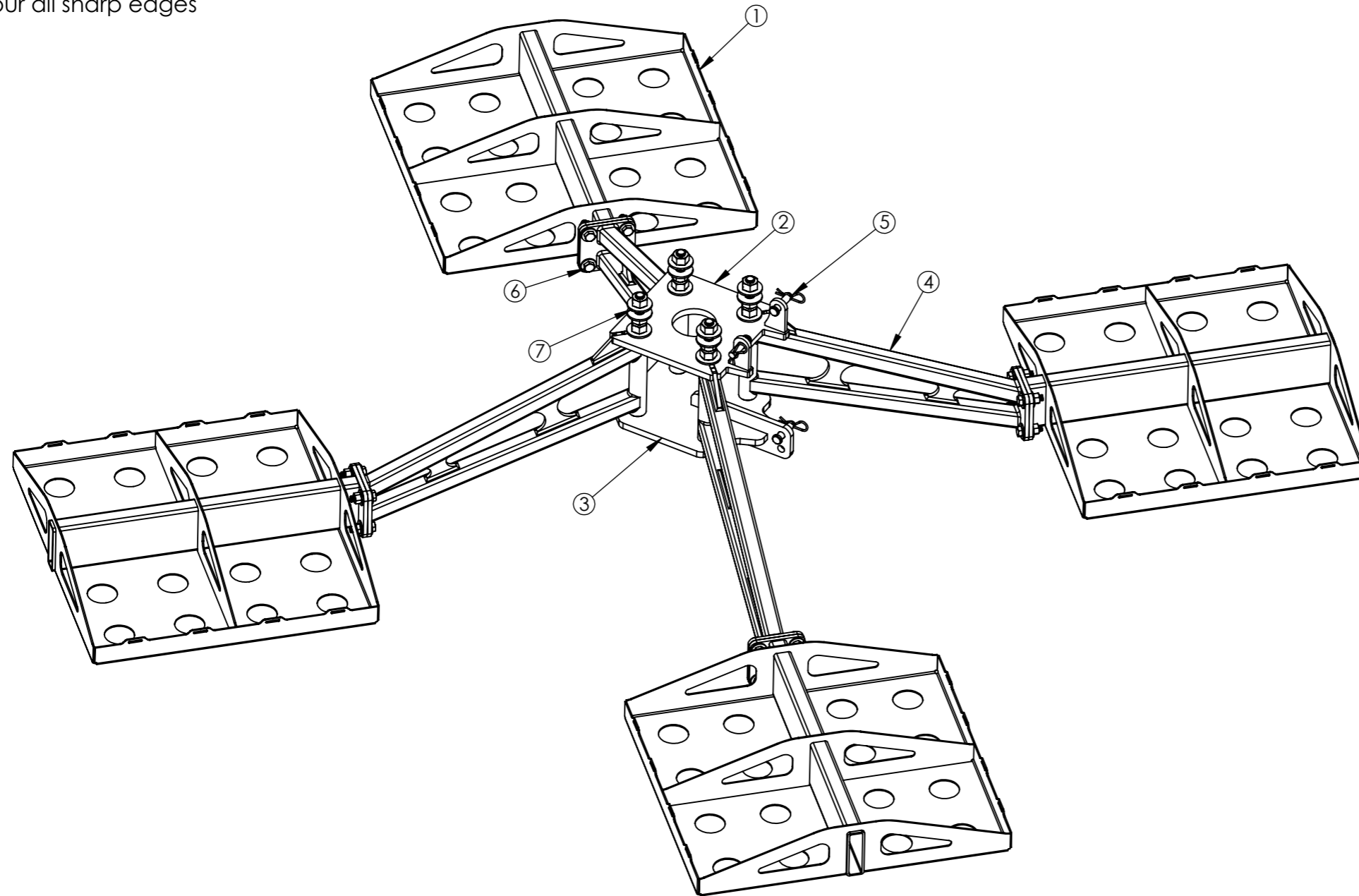

AFS200 Bolts, Nuts & Washers (other equivalent grades acceptable)

#	Unit	Bolt Size	Length	Width Across Flats	Thread Length	Grade	Coating	Nut Qty.	Washer Qty.	Bolt Qty.
6	Metric	M16x2	60mm	24mm	Full Thread	8.8	Hot Dip Galv.	16	32	16
6	Imperial	5/8-11	2.5"	15/16"	Full Thread	A325	Hot Dip Galv.	16	32	16
7	Metric	M24x3	445mm	36mm	150mm (min.)	8.8	Hot Dip Galv.	12	16	4
7	Imperial	1-8	17.5"	1.5"	6" (min.)	A325	Hot Dip Galv.	12	16	4

Does not include anchor bolts, templates or flange bolts	APPROVALS		DATE
	DRAWN	MGC	2/18/21
	CHECKED		
	RESP ENG		
MATERIAL	See Notes	MFG ENG	
FINISH	See Notes	QUAL ENG	
DO NOT SCALE DRAWING		scale NA	rev. A size NA 2 of 2

ARE Telecom & Wind
1041 Grand Ave., #213
St Paul, MN 55105
(651) 330 1263

AFS200-BOM

CAD file :
Details and dimensions not shown on this drawing can be found in CAD file